



Juno Future

Introduction of Construction Solutions

Juno Future Holdings Pty Ltd

A Future Trends Group Member Company





About Juno Future

- Most Advanced Self Owned Proprietary Technology
- In House Manufacturing Base in China
- Able to Set Up Manufacturing & Factories in Target Markets
- Can Self Invest Entirely
- Welcome to Joint Venture & Co-investments
- Plan to Capture Multiple Markets Globally
- Plan for Conglomerate Creation and/or Public Listings

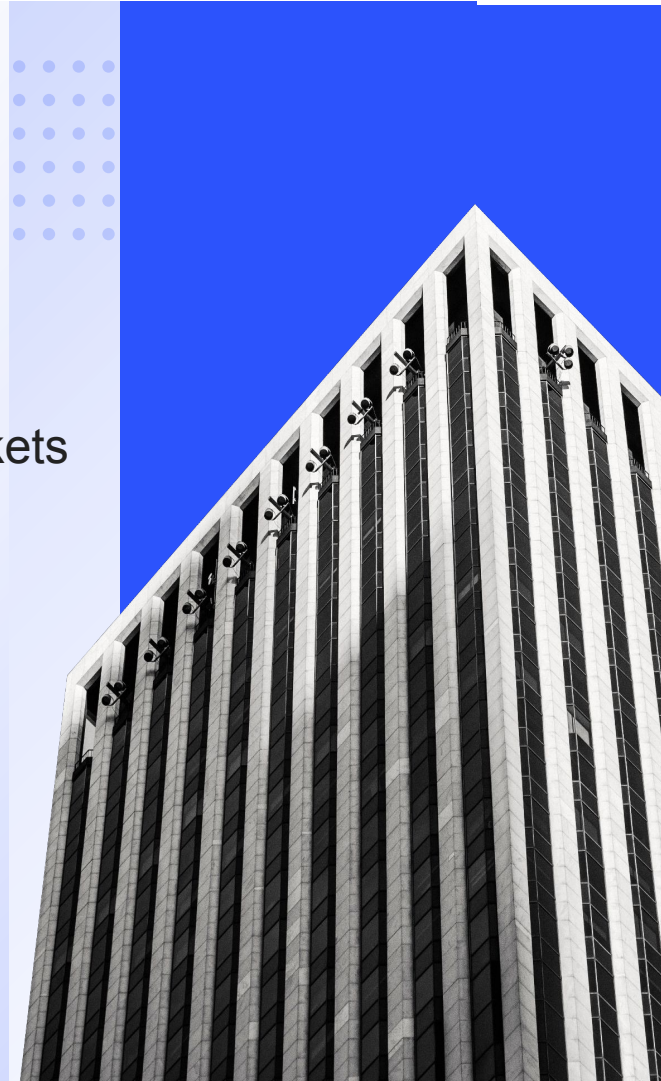



01

Building Models

Grounded in integrity, built through generations. We are the bedrocks of construction formwork



The first generation internal mold was slightly tapered, resulting in walls that were thicker at the top and thinner at the bottom



**Gen-2 Mold: Vertical walls, internal mold opening
outwards, external mold sliding**



Gen-3 Molds: All values are adjustable including heights, widths and lengths





Gen-4 Mold: Fully Automatic Mold



02

Split-type Precast Concrete Room Mold

Modular wall and roof panels for easy
transport and installation, featuring
advanced technical engineering









03

Various Boundary Wall & Fencing Molds

Widely used for factories, institutions, and livestock farming. The gold standard for fast construction and low cost







院墙，迎面墙，
广告牌



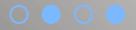

Precast Gateway Molds

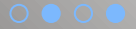
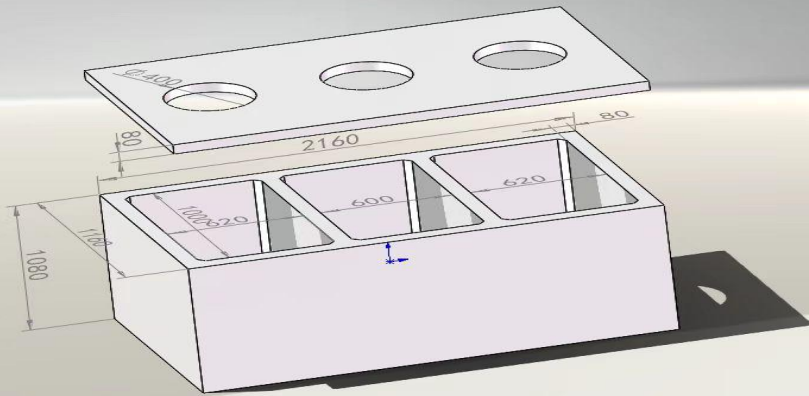

Septic Tank Molds



04

Foundation Molds and Construction Equipment

Professional teams and equipment,
providing reliable services to all customers











Lifting frame

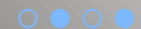

Steam curing cover



Gantry



**Steam generator:
Essential for
steam curing to
accelerate
setting and
ensure product
quality**



Fully Automated Concrete System







06

Photos with Clients

Highly acclaimed by a wide range of
customers





